

TECHNICAL DATA SHEET

505045909



■ REAR TRIPLE STUD FITTING
WEIGHT : 169 grs

FEATURES

Characteristics

Fitting class	Torque
Number of studs	3
Shear plunger	Yes
F _{xz} (for rear) / F _z (for front)	> 60 KN

Aircrafts

AIRBUS				BOEING				OTHERS
A320	A330	A350	A380	B737	B747	B767	B777	(*)
●	●	-	-	●	●	●	-	-

(*) Indicated for other platforms, contact ATTAX for more information

COMPONENTS

Material

Treatment

Body	Steel 4140 per AMS 6349	Zinc Nickel Type II Grade B per AMS 2417
Plunger	Steel 42CrMo4 per EN 10293	Zinc Nickel Type II Grade B per AMS 2417
Lever	--	--

DIMENSIONS

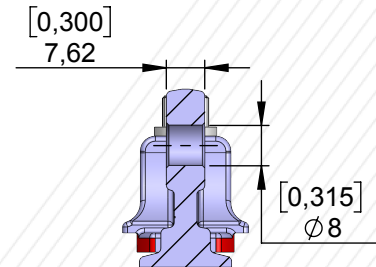
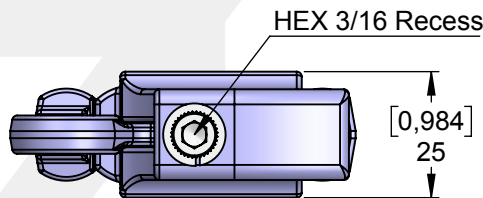
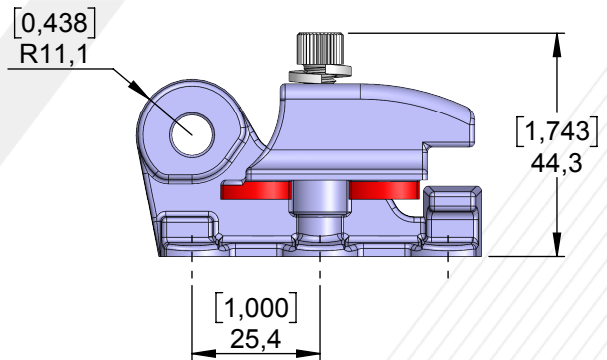
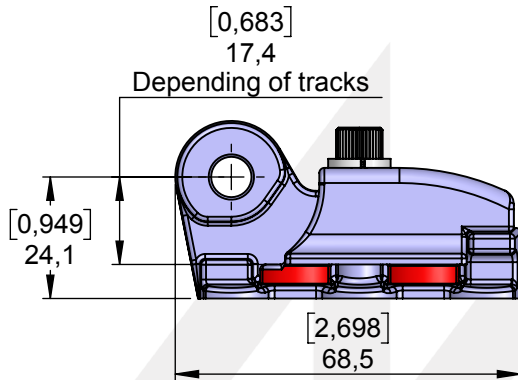

Technical data

Safety indicator	Yes	Tool-less	No	Secured locking	No
Red	Yes	Quick release	No	Offset	No
Green	No	Positive engagement	No	Captive screw	No

This document is the property of ATTAX and shall not be modified or disclosed without prior written authorization. © ATTAX 2019

Revision 28/03/2019