

# TECHNICAL DATA SHEET

## 50T3R1002-ZN



■ REAR TRIPLE STUD FITTING  
**WEIGHT : 144 grs**

### FEATURES

#### Characteristics

Fitting class	Torque
Number of studs	3
Shear plunger	Yes
F <sub>xz</sub> (for rear) / F <sub>z</sub> (for front)	> 60 KN

#### Aircrafts

AIRBUS				BOEING				OTHERS
A320	A330	A350	A380	B737	B747	B767	B777	(*)
●	●	-	-	●	●	●	-	-

(\*) Indicated for other platforms, contact ATTAX for more information

### COMPONENTS

#### Material

#### Treatment

Body	Steel 4140 per AMS 6349	Zinc Nickel Type II Grade B per AMS 2417
Plunger	Steel 42CrMo4 per EN 10293	Zinc Nickel Type II Grade B per AMS 2417
Lever	--	--

### DIMENSIONS

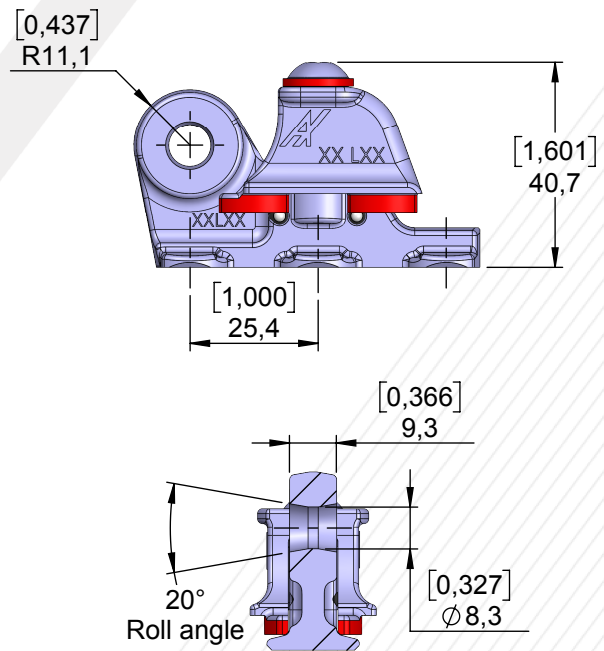
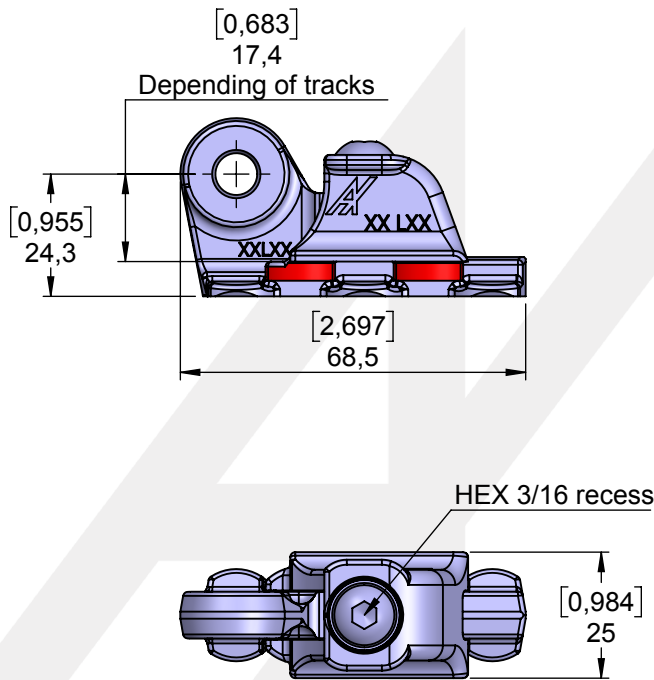

### Technical data

<b>Safety indicator</b>	Yes	<b>Tool-less</b>	No	<b>Secured locking</b>	Yes
<b>Red</b>	Yes	<b>Quick release</b>	No	<b>Offset</b>	No
<b>Green</b>	No	<b>Positive engagement</b>	Yes	<b>Captive screw</b>	Yes