



# TECHNICAL DATA SHEET

## 50T3R1001-ZN

■ REAR TRIPLE STUD FITTING  
**WEIGHT : 142 grs**

### FEATURES

Characteristics	
Fitting class	Torque
Number of studs	3
Shear plunger	Yes
F <sub>xz</sub> (for rear) / F <sub>z</sub> (for front)	> 60 KN

Aircrafts									
AIRBUS				BOEING				OTHERS	
A320	A330	A350	A380	B737	B747	B767	B777	(*)	
●	●	-	-	●	●	●	-	-	

(\*) Indicated for other platforms, contact ATTAX for more information

### COMPONENTS

Material		Treatment	
Body	Steel 4140 per AMS 6349	Zinc Nickel Type II Grade B per AMS 2417	
Plunger	Steel 42CrMo4 per EN 10293	Zinc Nickel Type II Grade B per AMS 2417	
Lever	--	--	

### DIMENSIONS

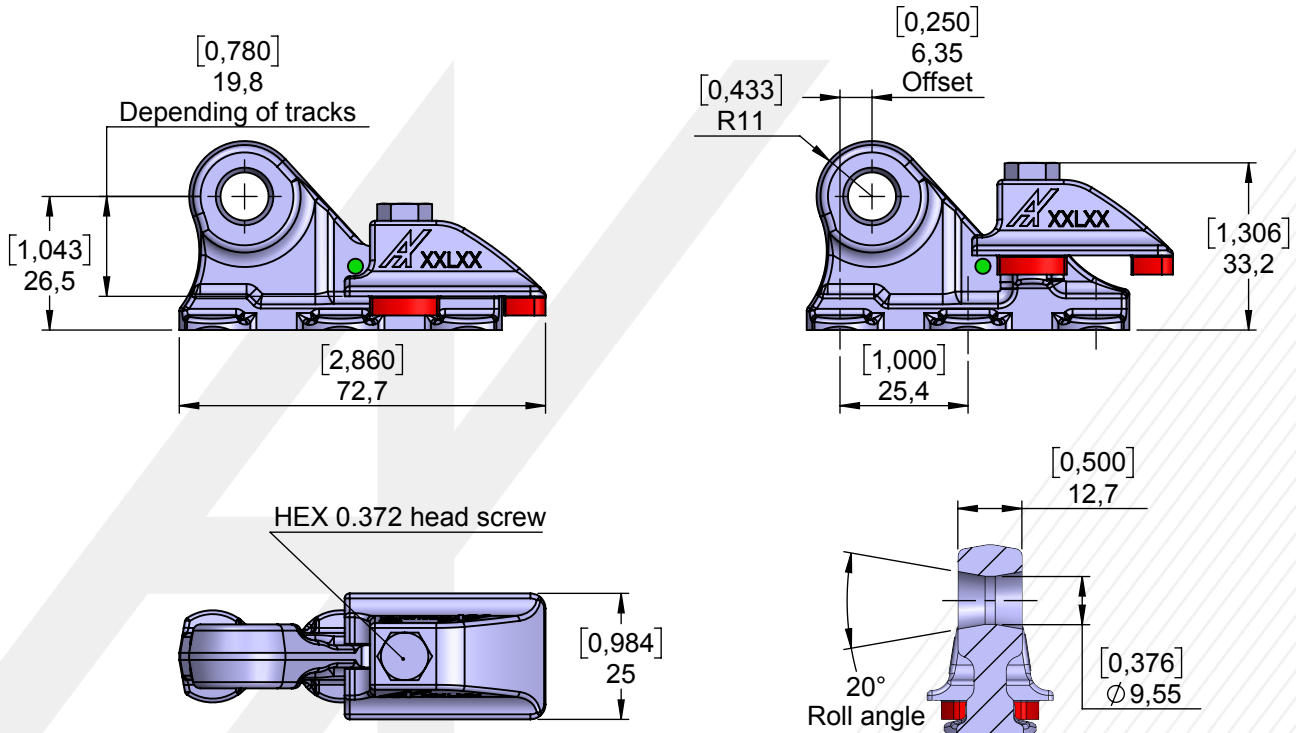

### Technical data

<b>Safety indicator</b>	Yes	<b>Tool-less</b>	No	<b>Secured locking</b>	No
<b>Red</b>	Yes	<b>Quick release</b>	No	<b>Offset</b>	Yes
<b>Green</b>	Yes	<b>Positive engagement</b>	No	<b>Captive screw</b>	No